

**ROTARY TILLER
UL-SERIES**

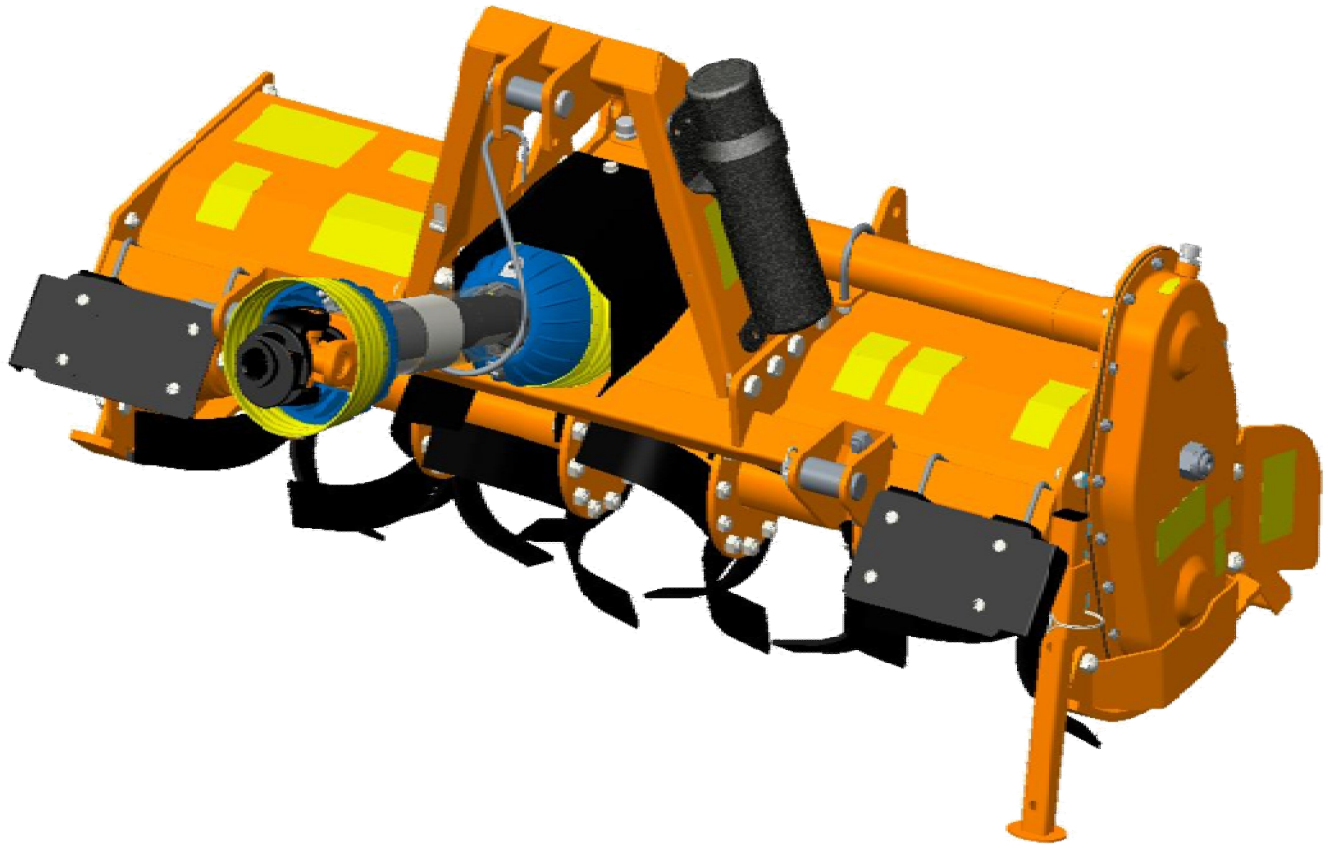

PART'S MANUAL

**Tirth Agro Technology Pvt. Ltd.
ISO 9001:2015 & CE Certified Company**



PM1121-21EN-011_AUG_19

INDEX

Page No.	Description	Revision Date
1.1	R D PLATE ASSEMBLY	PM1121-21EN-011_REV_000_AUG_19
1.2	R D PLATE ASSEMBLY	PM1121-21EN-011_REV_000_AUG_19
2.1	S D PLATE ASSEMBLY	PM1121-21EN-011_REV_000_AUG_19
2.2	S D PLATE ASSEMBLY	PM1121-21EN-011_REV_000_AUG_19
3.1	GEAR BOX ASSEMBLY	PM1121-21EN-011_REV_000_AUG_19
3.2	GEAR BOX ASSEMBLY	PM1121-21EN-011_REV_000_AUG_19
4.1	SIDE DRIVE & GEARBOX PARTS WITH FRAME	PM1121-21EN-011_REV_000_AUG_19
4.2	SIDE DRIVE & GEARBOX PARTS WITH FRAME	PM1121-21EN-011_REV_000_AUG_19
5.1	ROTOR, TOP MAST, TRAILING BOARD & STAND PARTS WITH FRAME	PM1121-21EN-011_REV_000_AUG_19
5.2	ROTOR, TOP MAST, TRAILING BOARD & STAND PARTS WITH FRAME	PM1121-21EN-011_REV_000_AUG_19
6.1	CE KIT ASSEMBLY (FOR CE MACHINES ONLY)	PM1121-21EN-011_REV_000_AUG_19
6.2	CE KIT ASSEMBLY (FOR CE MACHINES ONLY)	PM1121-21EN-011_REV_000_AUG_19

R D PLATE ASSEMBLY

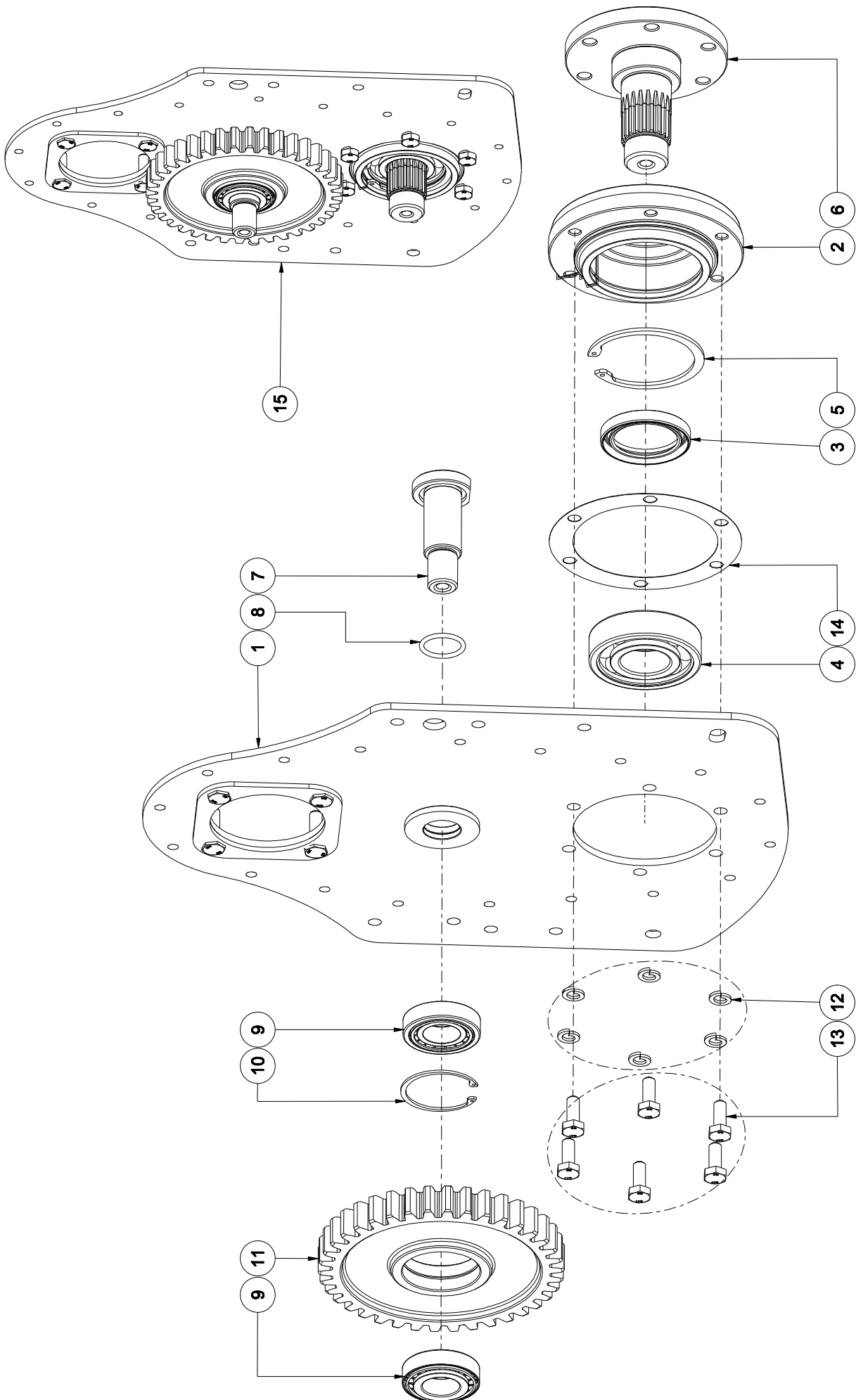

R D PLATE ASSEMBLY			
Sr No.	Part no	Description	Qty.
1	14320	R D PLATE GD COMP (U-SERIES)	1
2	14438	ROTOR SHAFT HOUSING V1 (U-SERIES)	1
3	14051	OIL SEAL 55 X 72 X 10	1
4	8036	BEARING 6308	1
5	3027	CIRCLIP INTERNAL 90MM	1
6	14022	R D SHAFT (U-SERIES)	1
7	14025	R D SHAFT SMALL (U-SERIES)	1
8	14131	O RING 30 x 3.50	1
9	14055	BEARING 30206	2
10	8120	CIRCLIP INTERNAL 62MM	1
11	14033	GEAR 38 TEETH (U-SERIES)	1
12	14361	SPRING WASHER M10.00(IS 3063)(ZP)	6
13	17270	HEX BOLT M10X1.50X25(DIN933)(8.8)(ZP)	6
14	14426	STUB AXLE COVER GASKET (U-SERIES) 0.4 CL	1
15	14077	R D PLATE ASSEMBLY (U-SERIES)	1

S D PLATE ASSEMBLY

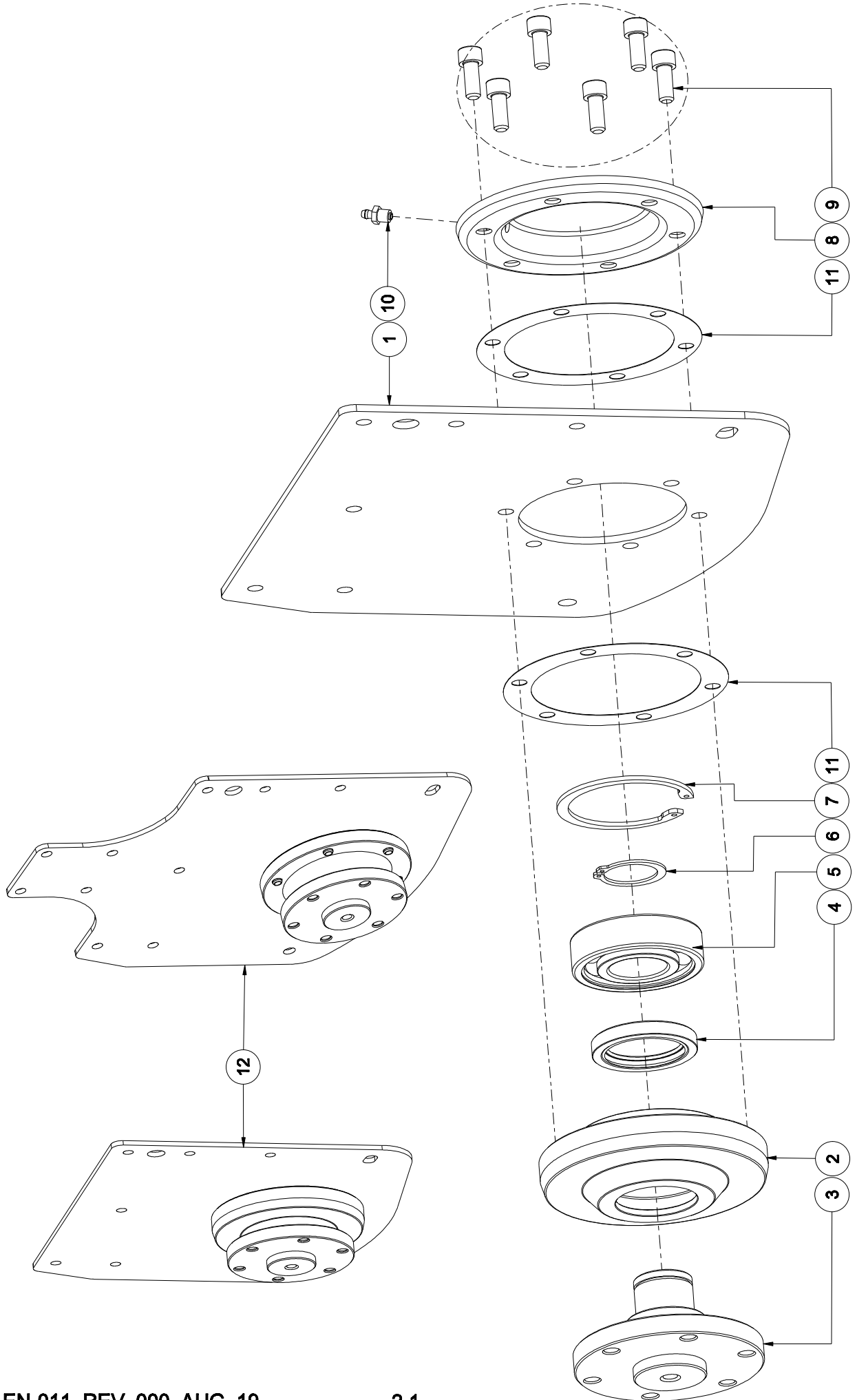

S D PLATE ASSEMBLY			
Sr No.	Part no	Description	Qty.
1	14023	S D PLATE (U-SERIES)	1
	14406	S D PLATE (F.H) (U-SERIES)	
2	14438	ROTOR SHAFT HOUSING V1 (U-SERIES)	1
3	14021	STUB AXLE SHAFT (U-SERIES)	1
4	14051	OIL SEAL 55 X 72 X 10	1
5	8036	BEARING 6308	1
6	8027	CIRCLIP EXTERNAL 40MM	1
7	3027	CIRCLIP INTERNAL 90MM	1
8	14256	SD PLATE END COVER COMP. (U-SERIES)	1
9	2833	ALLEN BOLT M10X1.5X25-FT-12.9DIN912-ZINC	6
10	1253	1/8 BSP GREASE NIPPLE 7.5MM	1
11	14426	STUB AXLE COVER GASKET (U-SERIES) 0.4 CL	2
12	14078	S D PLATE ASSEMBLY (U-SERIES)	1
	14409	S D PLATE ASSEMBLY (F.H) (U-SERIES)	

GEAR BOX ASSEMBLY

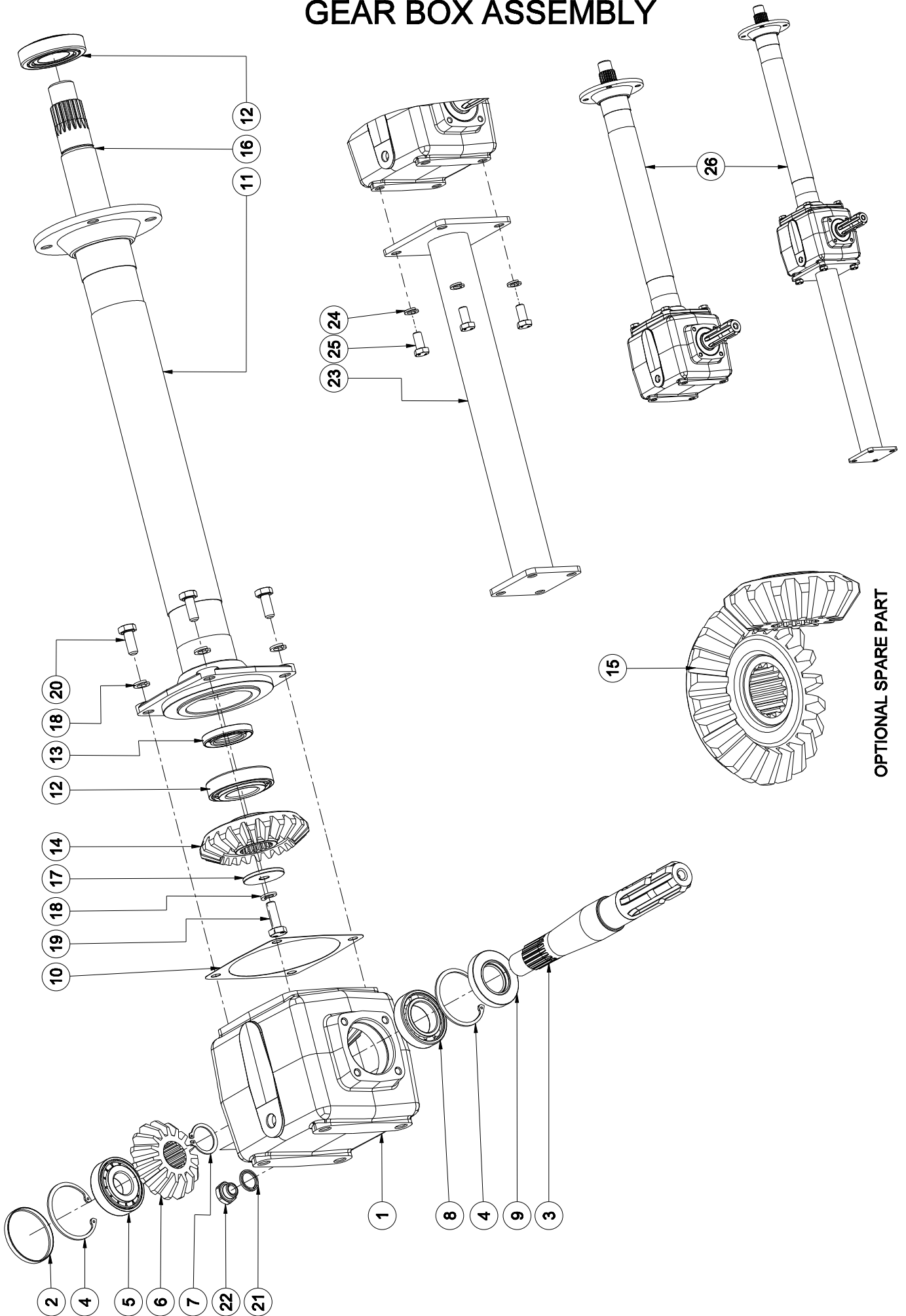

OPTIONAL SPARE PART

GEAR BOX ASSEMBLY			
Sr No.	Part no	Description	Qty.
1	14043	GEAR BOX 540 RPM (U-SERIES)	1
2	14075	OIL SEAL 62 X 7	1
3	14046	INPUT SHAFT (U-SERIES)	1
4	8120	CIRCLIP INTERNAL 62MM	2
5	14053	BEARING 30305	1
6	14047	PINION 15 TEETH (U-SERIES)	1
7	11058	EXTERNAL CIRCLIP 30MM	1
8	14054	BEARING 6007	1
9	14057	OIL SEAL 35 X 62 X 10	1
10	14428	J/S HOUSING GASKET GD (U-SERIES) 0.4 CL	1
11	10199	J/S HSG. (J-488.5) (EL-380.5) (U-SERIES)(0.90)	1
	10300	J/S HSG. (J-568) (EL-459.65) (U-SERIES)(1.05)	
	10206	J/S HSG. (J-541) (EL-433) (U-SERIES)(1.20)(SS)	
	14269	J/S HSG. (J-641) (EL-533) (U-SERIES)(1.20)(FH)(CM)	
	14006	J/S HSG. (J-793.5) (EL-685.5) (U-SERIES)(1.50)	
12	1003	BEARING 30207	2
13	14056	OIL SEAL 35 X 55 X 8	1
14	14048	CROWN 22 TEETH (U-SERIES)	1
15	14368	CROWN T22,PINION T15 PAIR (U-SERIES) (OPTIONAL PART)	1
16	10067	JACK SHAFT 488.5 MM (U-SERIES)(0.90)	1
	10301	JACK SHAFT 568 (U-SERIES)(1.05)	
	10205	JACK SHAFT 541 MM (U-SERIES)(1.20)(SS)	
	14268	JACK SHAFT 641 MM CM (U-SERIES)(1.20)(FH)(CM)	
	14045	JACK SHAFT 793.5 MM (U-SERIES)(1.50)	
17	14049	CROWN WASHER (U-SERIES)	1
18	14361	SPRING WASHER M10.00(IS 3063)(ZP)	5
19	3340	HEX BOLT M10X1.50X30(DIN933)(8.8)(ZP)	1
20	17270	HEX BOLT M10X1.50X25(DIN933)(8.8)(ZP)	4
21	19007	DOWTY SEAL (3/8 BSP)	1
22	14312	DRAIN CAP 3/8" BSP (1GTC02UW)	1
23	14404	FULL HSG. COMP (U-SERIES)(1.20)(FH)	1
	14411	FULL HSG. COMP (U-SERIES)(1.50)(FH)	
24	14362	SPRING WASHER M12.00(IS 3063)(ZP)	4
25	17474	HEX BOLT M12X1.75X25(DIN933)(8.8)(ZP)	4
26	10204	GEAR BOX ASSEMBLY 540 RPM (U-SERIES)(0.90)	1
	10302	GEAR BOX ASM. 540 RPM (U-SERIES)(1.05)	
	14408	GEAR BOX ASM. 540 RPM CM F.H. (U-SERIES)(1.20)(FH)	
	10211	GEAR BOX ASSEMBLY 540 RPM (U-SERIES)(1.20)(SS)	
	14270	GEAR BOX ASM. 540 RPM 639M (U-SERIES)(1.20)(CM)	
	14412	GEAR BOX ASM. 540 RPM FH (U-SERIES)(1.50)(FH)	
	14079	GEAR BOX ASSEMBLY 540 RPM (U-SERIES)(1.50)	

SIDE DRIVE & GEARBOX PARTS WITH FRAME

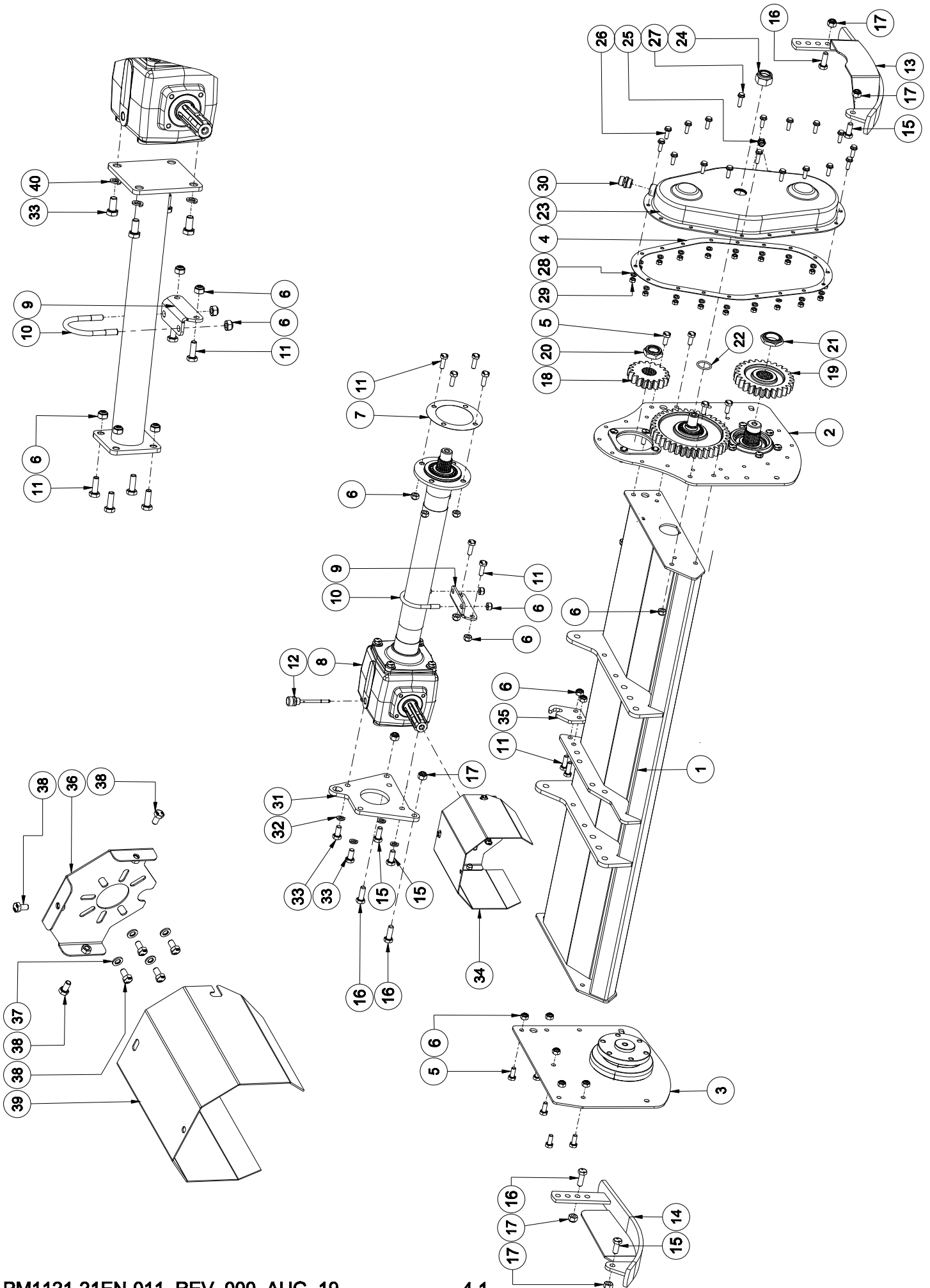

SIDE DRIVE & GEARBOX PARTS WITH FRAME			
Sr No.	Part no	Description	Qty.
1	10200	HULL COMP 0.9M (U-SERIES)	1
	10297	HULL COMP 1.05M (U-SERIES)	
	10207	HULL COMP 1.2M (U-SERIES)	
	14271	HULL COMP 1.2M CM (U-SERIES)	
	14405	HULL COMP. CM DS 1.2M (U-SERIES)	
	14001	HULL COMP 1.5M (U-SERIES)	
	14410	HULL COMP. CM DS 1.5M (U-SERIES)	
2	14077	R D PLATE ASSEMBLY (U-SERIES)	1
3	14078	S D PLATE ASSEMBLY (U-SERIES)	1
	14409	S D PLATE ASSEMBLY (F.H) (U-SERIES)	
4	14371	CHAIN COVER PAPER GASKET (U-SERIES)	1
5	17270	HEX BOLT M10X1.50X25(DIN933)(8.8)(ZP)	9
6	1298	NYLOCK NUT M10X1.50 (DIN-982)	19
		NYLOCK NUT M10X1.50 (DIN-982)(FOR FH)	27
7	14427	J/S HOUSING GASKET RD (U-SERIES) 0.4 CL	1
8	10204	GEAR BOX ASSEMBLY 540 RPM (U-SERIES)(0.90)	1
	10302	GEAR BOX ASM. 540 RPM (U-SERIES)(1.05)	
	14408	GEAR BOX ASM. 540 RPM CM F.H. (U-SERIES)(1.20)(FH)	
	10211	GEAR BOX ASSEMBLY 540 RPM (U-SERIES)(1.20)(SS)	
	14270	GEAR BOX ASM. 540 RPM 639M (U-SERIES)(1.20)(CM)	
	14412	GEAR BOX ASM. 540 RPM FH (U-SERIES)(1.50)(FH)	
	14079	GEAR BOX ASSEMBLY 540 RPM (U-SERIES)(1.50)	
9	14027	JACK SHAFT HOUSING MOUN PLATE (U-SERIES)	1
		JACK SHAFT HOUSING MOUN PLATE (U-SERIES)(FOR FH)	2
10	14420	U BOLT M10X1.5X71.00X90.00X24 TL (8.8)	1
		U BOLT M10X1.5X71.00X90.00X24 TL (8.8)(FOR FH)	2
11	3340	HEX BOLT M10X1.50X30(DIN933)(8.8)(ZP)	8
		HEX BOLT M10X1.50X30(DIN933)(8.8)(ZP)(FOR FH)	14
12	14317	DIPSTICK 90MM (M16 X 1.5) (1MLSR203)	1
13	14009	DEPTH SKID COMP LH (U-SERIES)	1
14	14010	DEPTH SKID COMP RH (U-SERIES)	1
15	17275	HEX BOLT M12X1.75X30(DIN933)(8.8)(ZP)	4
16	17274	HEX BOLT M12X1.75X35(DIN933)(8.8)(ZP)	4
17	1209	NYLOCK NUT M12X1.75 (DIN-982)	6
18	14032	GEAR 18 TEETH (U-SERIES)	1
19	14034	GEAR 27 TEETH (U-SERIES)	1
20	14366	NYLOCK NUT M28 X 1.50	1
21	1449	NYLOCK NUT M35X1.50	1
22	14131	O RING 30 x 3.50	1
23	14443	SIDE COVER GD COMP (U-SERIES) NEW	1
24	14065	NYLOCK NUT M24X2.00 (DIN-982)	1
25	14313	OIL LEVEL GAUGE 1/4" BSP (1GTLN110)	1
26	14441	FLANGE BOLT M8X1.25X25(DIN6921)(8.8)(ZP)	16
27	14442	FLANGE BOLT M8X1.25X30(DIN6921)(8.8)(ZP)	2
28	14360	SPRING WASHER M8.00(IS 3063)(ZP)	18
29	8181	HEX NUT M8X1.25(IS 1363)(8)(ZP)	18
30	14310	AIR BREATHER 1/2" BSP (1GTSR38)	1
31	14042	GEAR BOX MOUN PLATE (U-SERIES)	1
32	14339	SPRING WASHER 1/2"(ASME B 18.21.1)	4
33	17474	HEX BOLT M12X1.75X25(DIN933)(8.8)(ZP)	2
		HEX BOLT M12X1.75X25(DIN933)(8.8)(ZP)(FOR FH)	6
34	14172	PTO SHAFT GUARD ASSEMBLY (SMALL)	1
35	14258	CHAIN LIFTING HOOK (U-SERIES)	1
36	14171	PTO SHAFT GUARD MOUNT PLATE COMP (SMALL)	1
37	8064	PLAIN WASHER 8MM (BS-4320)	4
38	8190	HEX BOLT M8X1.25X15(IS1364-2)(8.8)(ZP)	7
39	14170	PTO SHAFT GUARD (SMALL)	1
40	14362	SPRING WASHER M12.00(IS 3063)(ZP)	4

ROTOR, TOP MAST, TRAILING BOARD & STAND PARTS WITH FRAME

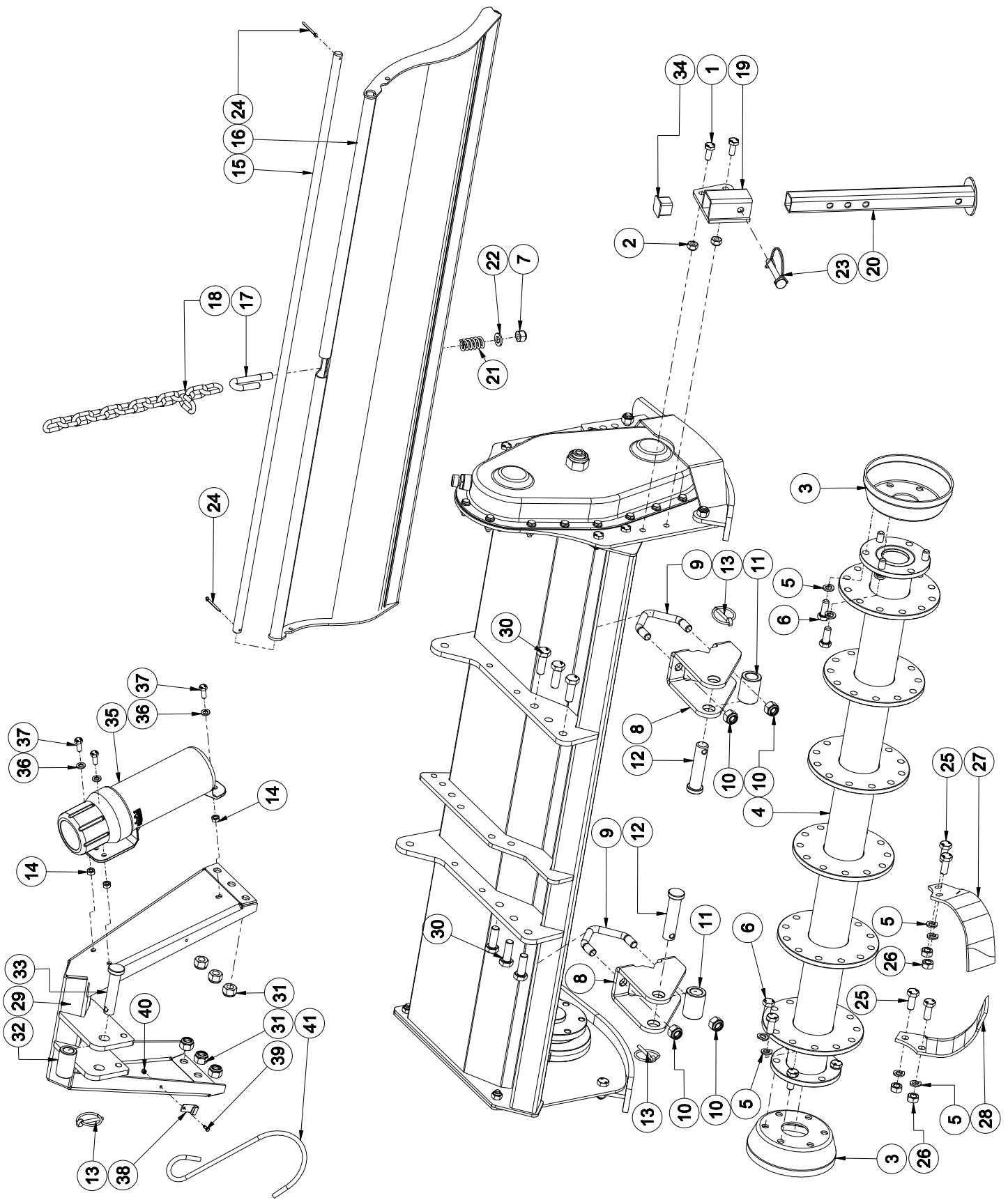

ROTOR, TOP MAST, TRAILING BOARD & STAND PARTS WITH FRAME			
Sr No.	Part no	Description	Qty.
1	17270	HEX BOLT M10X1.50X25(DIN933)(8.8)(ZP)	2
2	1298	NYLOCK NUT M10X1.50 (DIN-982)	2
3	14020	DUST COVER (U-SERIES)	2
4	10202	ROTOR SRT-0.9M C/L-TYPE (U-SERIES)(60X6)	1
	10298	ROTOR SRT-1.05M C/L-TYPE(U-SERIES)(60X6)	
	10209	ROTOR SRT-1.2M C/L-TYPE (U-SERIES)(60X6)	
	14002	ROTOR SRT-1.5M C/L-TYPE (U-SERIES)(60X6)	
5	14339	SPRING WASHER 1/2"(ASME B 18.21.1)(0.90)	60
		SPRING WASHER 1/2"(ASME B 18.21.1)(1.05)	72
		SPRING WASHER 1/2"(ASME B 18.21.1)(1.20)	84
		SPRING WASHER 1/2"(ASME B 18.21.1)(1.50)	96
6	17275	HEX BOLT M12X1.75X30(DIN933)(8.8)(ZP)	12
7	1209	NYLOCK NUT M12X1.75 (DIN-982)	1
8	14378	NEW HITTING BRACKET COMP (U-SERIES)	2
9	14424	V-BOLT M14X2X90X78X23 TL (8.8)	2
10	1574	NYLOCK NUT M14X2.00 (DIN-982)	4
11	14016	BUSH (DIA. 36.5 X 22.5 X 50 L)	2
12	14015	HITCH PIN BOTTOM CAT-I (DIA-22 X 99)	2
13	8204	LINCH PIN SMALL (CHO)	3
14	8181	HEX NUT M8X1.25(IS 1363)(8)(ZP)	3
15	10203	TRAILING BOARD ROD 0.9M (U-SERIES)	1
	10303	TRAILING BOARD ROD 1.05M (U-SERIES)	
	10210	TRAILING BOARD ROD 1.2M (U-SERIES)	
	14050	TRAILING BOARD ROD 1.5M (U-SERIES)	
16	10201	TRAILING BOARD COMP 0.9M (U-SERIES)	1
	10299	TRAILING BOARD COMP 1.05M (U-SERIES)	
	14272	TRAILING BOARD COMP 1.2M (U-SERIES)(CM)	
	10208	TRAILING BOARD COMP 1.2M (U-SERIES)(SS)	
	14003	T B COMP 1.5M (U-SERIES)	
17	14004	J-BOLT M12 x 1.75 x 24 x 87.5 x 25TL	1
18	14073	LIFTING CHAIN TB	1
19	14012	M/C MOUN STAND COMP (U-SERIES)	1
20	14013	M/C STAND PIPE COMP (U-SERIES)	1
21	14005	U-BOLT SPRING (U-SERIES)	1
22	8126	PLAIN WASHER 12MM (BS-4320)	1
23	14267	SQ. SNAPPER PIN D10 X L70	1
24	19018	COTTER PIN (DIA 4 X 35)	2
25	14324	HEX BOLT M12 X 1.25 X 30(HT-10.9)DIN 960(0.90)	48
		HEX BOLT M12 X 1.25 X 30(HT-10.9)DIN 960(1.05)	60
		HEX BOLT M12 X 1.25 X 30(HT-10.9)DIN 960(1.20)	72
		HEX BOLT M12 X 1.25 X 30(HT-10.9)DIN 960(1.50)	84
26	14336	HEX NUT M12X1.25(DIN 934)(10)(ZP)(0.90)	48
		HEX NUT M12X1.25(DIN 934)(10)(ZP)(1.05)	60
		HEX NUT M12X1.25(DIN 934)(10)(ZP)(1.20)	72
		HEX NUT M12X1.25(DIN 934)(10)(ZP)(1.50)	84
27	14040	BLADE C-TYPE RH (60X6)(156X113)(0.90)	12
		BLADE C-TYPE RH (60X6)(156X113)(1.05)	15
		BLADE C-TYPE RH (60X6)(156X113)(1.20)	18
		BLADE C-TYPE RH (60X6)(156X113)(1.50)	21
28	14041	BLADE C-TYPE LH (60X6)(157X117)(0.90)	12
		BLADE C-TYPE LH (60X6)(157X117)(1.05)	15
		BLADE C-TYPE LH (60X6)(157X117)(1.20)	18
		BLADE C-TYPE LH (60X6)(157X117)(1.50)	21
29	14375	NEW TOP MAST COMP. (U-SERIES)	1
30	23318	HEX BOLT M14X1.50X40(DIN931)(8.8)(ZP)	6
31	1302	NYLOCK NUT M14X1.50 (DIN-982)	6
32	14038	BUSH (DIA. 19.5 X 31.5 X 52 L)	1
33	14037	HINCH PIN TOP CAT-I (DIA- 19 X 98)	1
34	14266	SQ. PIPE PLASTIC CAP 32MM	1
35	26030	MANUAL BOX COVER 1/2(SMMSD)	1
36	8064	PLAIN WASHER 8MM (BS-4320)	3
37	8040	HEX BOLT M8X1.25X20(IS1364-2)(8.8)(ZP)	3
38	23147	PLATE,HOOK HOLDING (JUMBO)	1
39	35098	HEX BOLT M4X0.75X15(IS1364-2)(8.8)(ZP)	1
40	24529	NYLOCK NUT M4 X 0.75 - SCH	1
41	14340	DRIVELINE HOOK 250MM	1

CE KIT ASSEMBLY (FOR CE MACHINES ONLY)

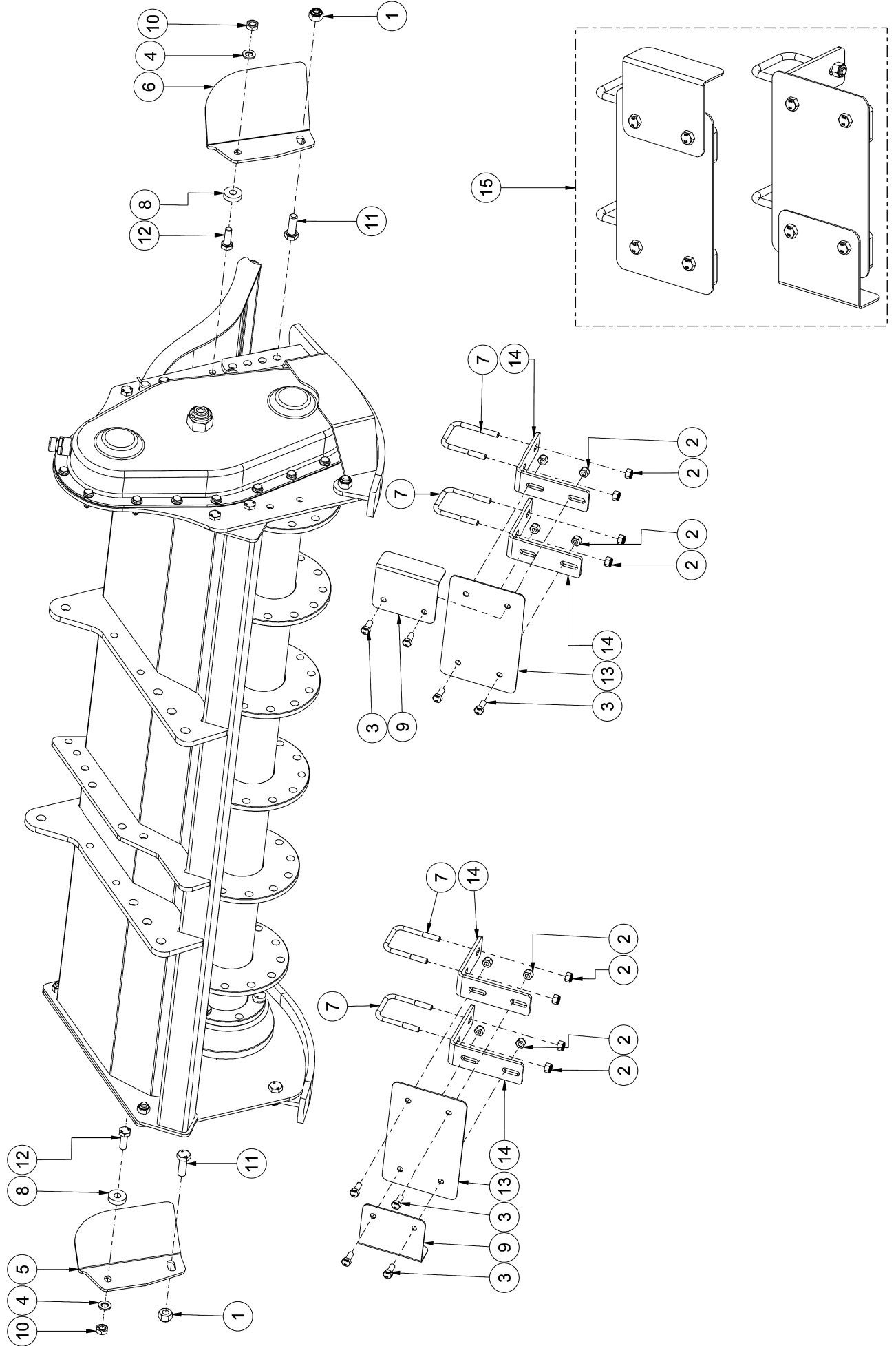

CE KIT ASSEMBLY (FOR CE MACHINES ONLY)			
Sr No.	Part no	Description	Qty.
1	1209	NYLOCK NUT M12X1.75 (DIN-982)	2
2	1297	NYLOCK NUT M8X1.25 (DIN-982)(0.90)	8
		NYLOCK NUT M8X1.25 (DIN-982)(1.20)(SS)	12
		NYLOCK NUT M8X1.25 (DIN-982)(1.05)(1.20 (CM))(1.50)	16
3	8040	HEX BOLT M8X1.25X20(IS1364-2)(8.8)(ZP)(0.90)	4
		HEX BOLT M8X1.25X20(IS1364-2)(8.8)(ZP)(1.20)(SS)	6
		HEX BOLT M8X1.25X20(IS1364-2)(8.8)(ZP)(1.05)(1.20 (CM))(1.50)	8
4	8078	PLAIN WASHER 10MM (BS-4320)	2
5	14183	TB GAURD PLATE LH (U-SERIES)	1
6	14184	TB GAURD PLATE RH (U-SERIES)	1
7	14190	U-BOLT M8 X 1.25 X 77 X 60 X 28TL(0.90)	2
		U-BOLT M8 X 1.25 X 77 X 60 X 28TL(1.20)(SS)	3
		U-BOLT M8 X 1.25 X 77 X 60 X 28TL(1.05)(1.20 (CM))(1.50)	4
8	14194	SPACER DIA-28 x 11 x 8 MM	2
9	4741	PLATE,END,FRONT BARRIER (REG +)	2
10	1299	HEX NUT M10X1.50(IS 1363)(8)(ZP)	2
11	17274	HEX BOLT M12X1.75X35(DIN933)(8.8)(ZP)	2
12	6068	HEX BOLT M10X1.50X35(IS1364-1)(8.8)(ZP)	2
13	14325	PLATE,FRONT BARRIER (125 X L=55)(0.90)	2
	4739	PLATE,FRONT BARRIER (L=100) (REG +)(1.05)	2
	4740	PLATE,FRONT BARRIER (L=300) (REG +)(1.20)(SS)	1
		PLATE,FRONT BARRIER (L=300) (REG +)(1.50)	2
	14326	PLATE,FRONT BARRIER (125 X L=200)(1.20)(CM)	2
	4781	PLATE,FRONT BARRIER (L=75) (REG +)(1.20)(SS)	1
14	14425	BRACKET,FRONT BARRIER (U-SERIES)(0.90)	2
		BRACKET,FRONT BARRIER (U-SERIES)(1.20)(SS)	3
		BRACKET,FRONT BARRIER (U-SERIES)(1.05)(1.20 (CM))(1.50)	4
15	14332	CE KIT NEW SRT-0.9 (U-SERIES)	1
	10304	CE KIT SRT-1.05M (U-SERIES)	
	14333	CE KIT NEW SRT-1.2 (U-SERIES)	
	14334	CE KIT NEW SRT-1.2 CM (U-SERIES)	
	14335	CE KIT NEW SRT-1.5 (U-SERIES)	



J.S. Woodhouse Co., Inc.

1314 Union Street

West Springfield, MA 01089

Tel: 413-736-5462

FAX 413- 732-3786